

FILENAME: TRD-T33

REVDATE: 0624

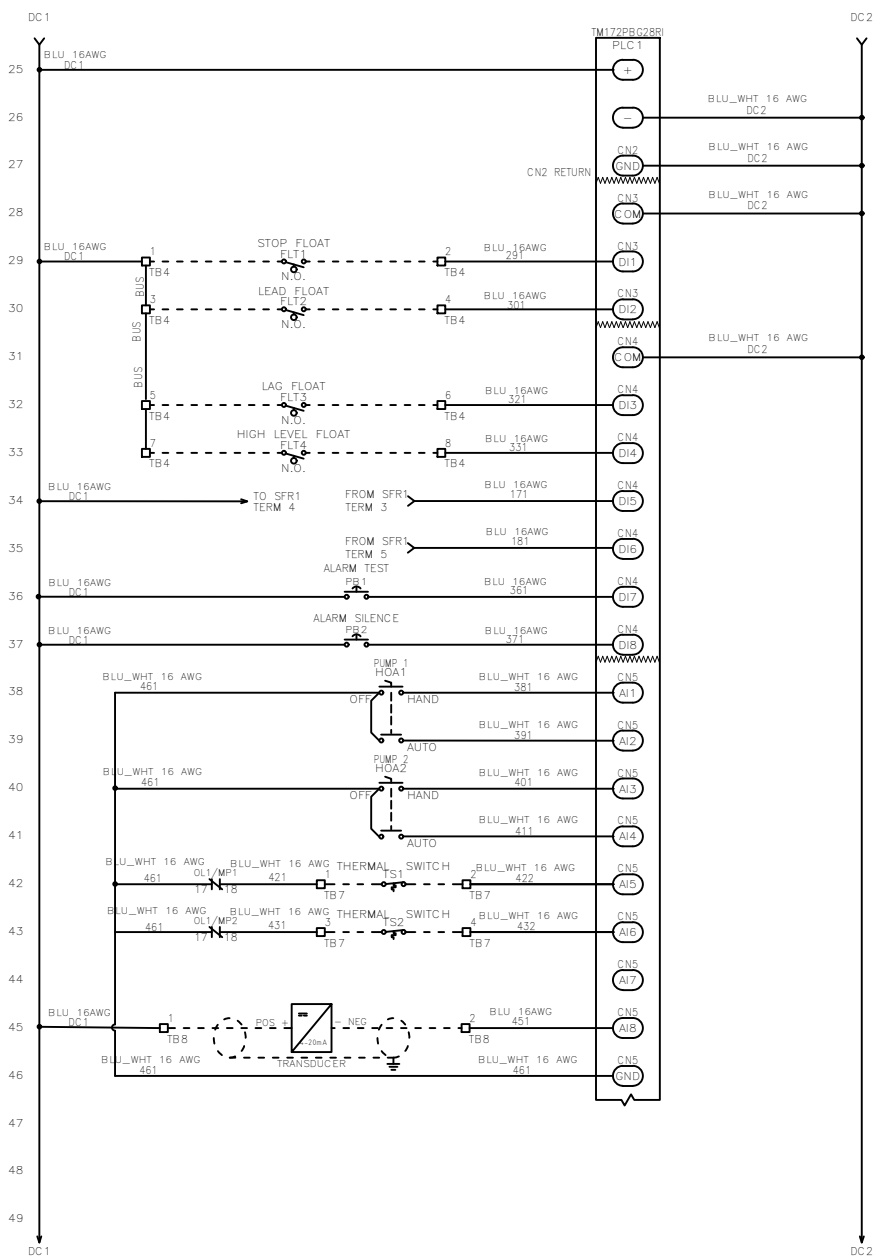
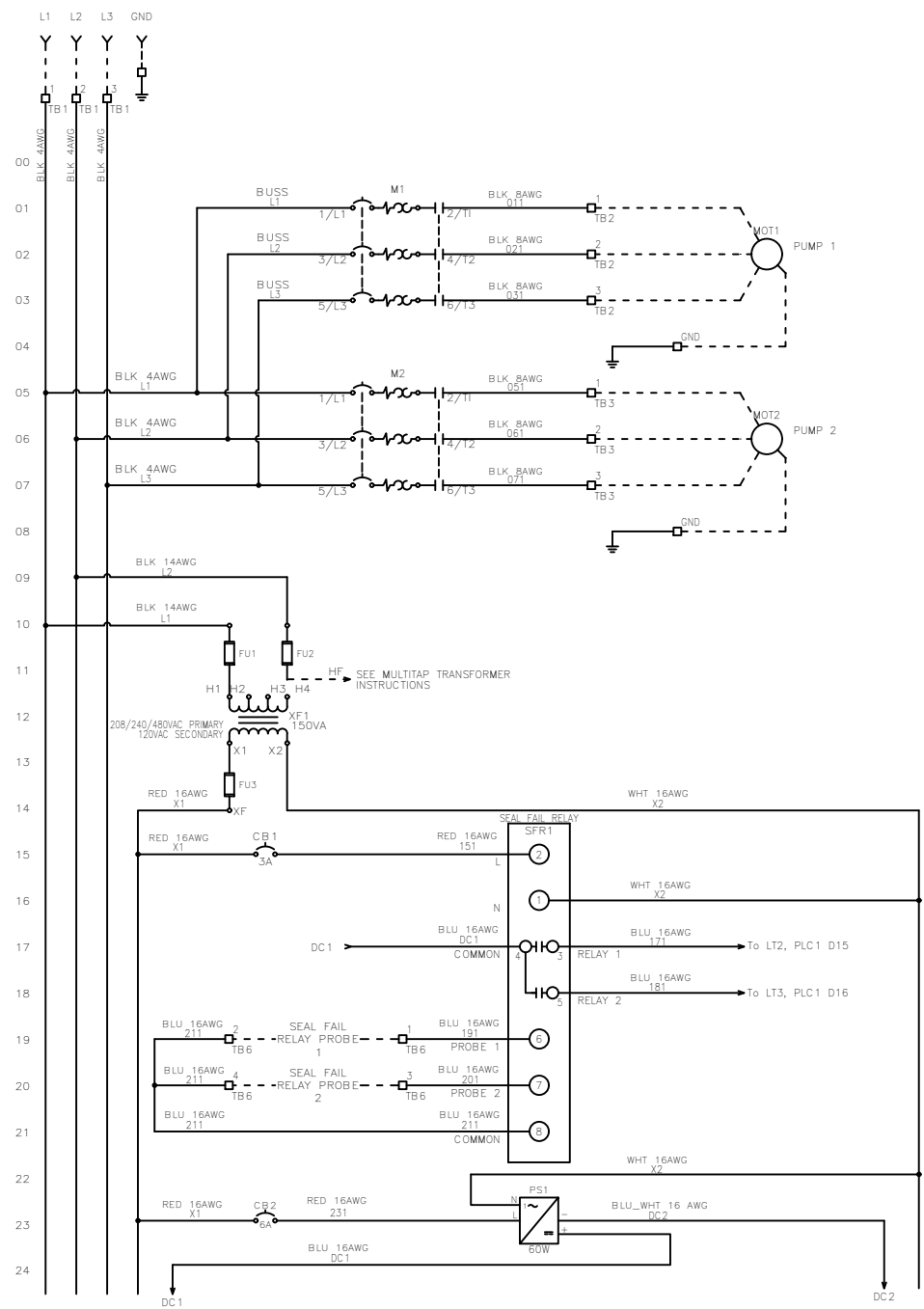

MULTI-TAP TRANSFORMER:

CONNECT FACTORY TAGGED WIRES TO APPROPRIATE TRANSFORMER VOLTAGE TAP. SEE BELOW FOR CONNECTIONS:

FOR 208V OPERATION, CONNECT TO FUSE INPUT HF & TO TRANSFORMER TAP H2.

FOR 240V OPERATION, CONNECT TO FUSE INPUT HF & TO TRANSFORMER TAP H3.

FOR 480V OPERATION, CONNECT TO FUSE INPUT HF & TO TRANSFORMER TAP H4.

----- DASHED LINE INDICATES FIELD WIRING.

USE COPPER CONDUCTORS ONLY.

TEMPERATURE RATING OF CONDUCTORS IS TO BE: 60°C (140°F) FOR UNDER 100A. 75°C (167°F) FOR OVER 100A.

BRANCH CIRCUIT PROTECTION SHALL BE PROVIDED BY THE INSTALLER: MUST BE SIZED ACCORDING TO PUMP/MOTOR MANUFACTURING SPECIFICATIONS.

VERIFY CORRECT OPERATION OF CONTROL PANEL AFTER INSTALLATION IS COMPLETE.

FIELD WIRING TORQUE SPECS.

TERMINAL BLOCK UT 2,5	5 IN-LB
TERMINAL BLOCK UT 4	7 IN-LB
TERMINAL BLOCK UT 6	15 IN-LB
TERMINAL BLOCK UT 10	15 IN-LB
TERMINAL BLOCK UT 16	25 IN-LB
TERMINAL BLOCK UT 35	30 IN-LB
TS1, TS2, J2 & J3 PCB	5 IN-LB
TRANSFORMER H1F, H2F & H3F	15 IN-LB
TRANSFORMER H1, H2 & H3	10 IN-LB
DS1 VLS3P63-125 R2	45 IN-LB
DS1 LK4JU3CN 100A	36 IN-LB
DS1 LK4MU3N 200A	200 IN-LB
M1/ M2 T1, T2 & T3	15 IN-LB

UL #:	E320866
TOTAL FLA:	66 A
LARGEST MOT. FLA	32 A
VOLTAGE:	208/240/480 VAC
PHASE:	3 PH
FREQUENCY:	60 Hz
ENCLOSURE TYPE:	3R
SHORT CIRCUIT CURRENT:	5KA RMS SYMMETRICAL 600V MAXIMUM

DRAWN BY:	JED	DATE:	08/28/20
APPROVED BY:	DO	DATE:	06/19/24
THIS DRAWING CONTAINS PROPRIETARY INFORMATION AND SHALL NOT BE USED OR DISCLOSED WITHOUT PRIOR WRITTEN AUTHORIZATION.			



TITLE: TRD-T33 SCHEMATIC			
SIZE	DWG NO.	PART NO.	REV
B	1838		F
SCALE	NONE	SHEET	1 OF 2

FNAME: TRD-T33

REVDATE: 0624

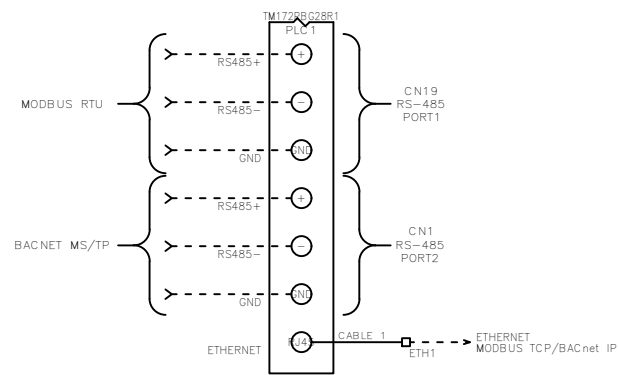
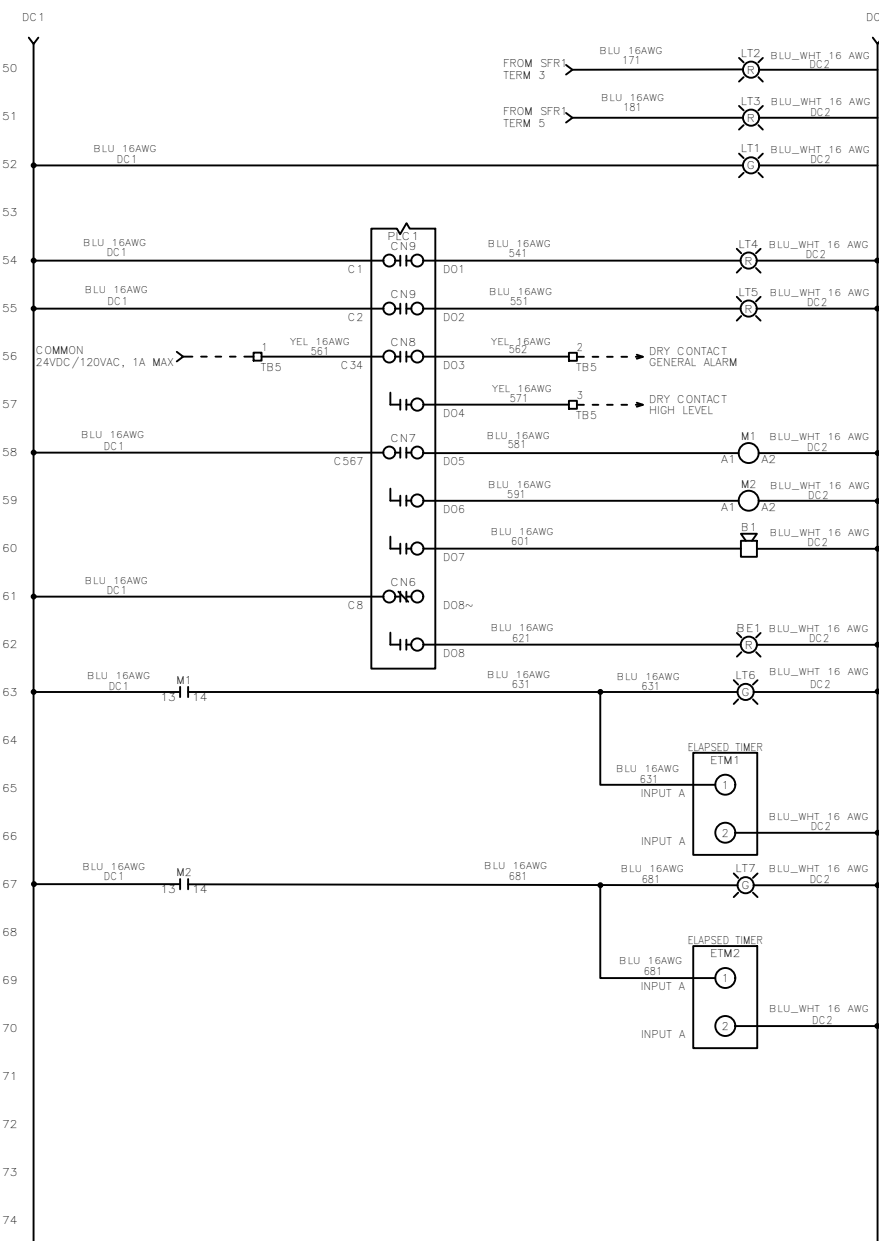

FIELD WIRING CONNECTIONS

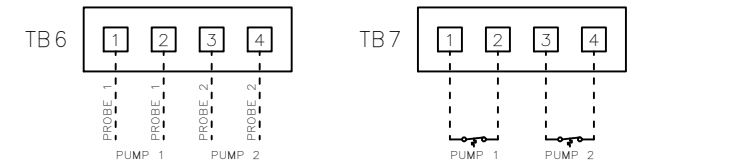
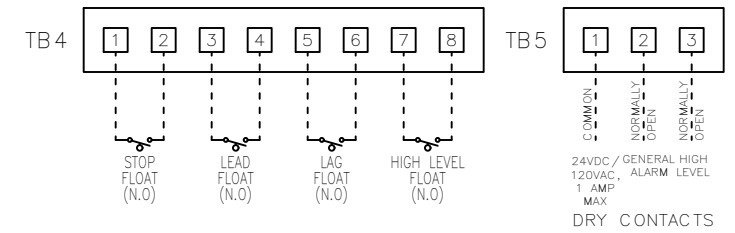
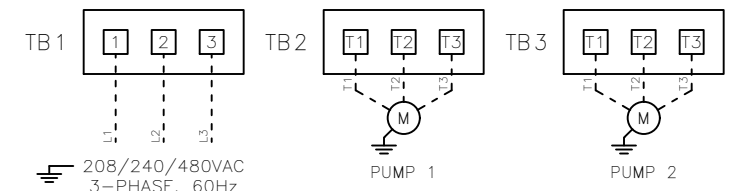

TRANSFORMER FIELD WIRING

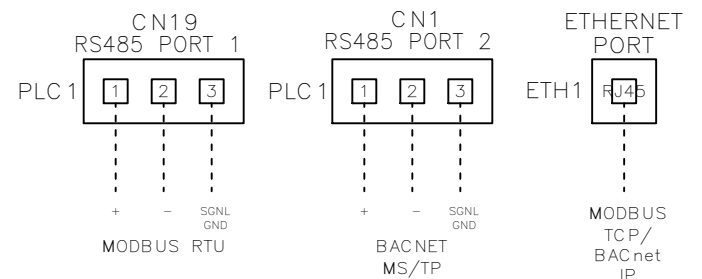
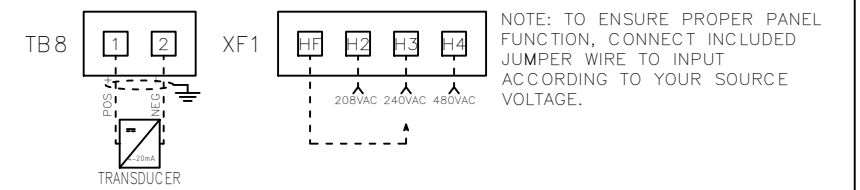

MULTI-TAP TRANSFORMER:

CONNECT FACTORY TAGGED WIRES TO APPROPRIATE TRANSFORMER VOLTAGE TAP. SEE BELOW FOR CONNECTIONS:

FOR 208V OPERATION, CONNECT TO FUSE INPUT HF & TO TRANSFORMER TAP H2.

FOR 240V OPERATION, CONNECT TO FUSE INPUT HF & TO TRANSFORMER TAP H3.

FOR 480V OPERATION, CONNECT TO FUSE INPUT HF & TO TRANSFORMER TAP H4.

----- DASHED LINE INDICATES FIELD WIRING.

USE COPPER CONDUCTORS ONLY.

TEMPERATURE RATING OF CONDUCTORS IS TO BE: 60°C (140°F) FOR UNDER 100A. 75°C (167°F) FOR OVER 100A.

BRANCH CIRCUIT PROTECTION SHALL BE PROVIDED BY THE INSTALLER: MUST BE SIZED ACCORDING TO PUMP/MOTOR MANUFACTURING SPECIFICATIONS.

VERIFY CORRECT OPERATION OF CONTROL PANEL AFTER INSTALLATION IS COMPLETE.

FIELD WIRING TORQUE SPECS.

TERMINAL BLOCK UT 2,5	5 IN-LB
TERMINAL BLOCK UT 4	7 IN-LB
TERMINAL BLOCK UT 6	15 IN-LB
TERMINAL BLOCK UT 10	15 IN-LB
TERMINAL BLOCK UT 16	25 IN-LB
TERMINAL BLOCK UT 35	30 IN-LB
TS1, TS2, J2 & J3 PCB	5 IN-LB
TRANSFORMER H1F, H2F & H3F	15 IN-LB
TRANSFORMER H1, H2 & H3	10 IN-LB
DS1 VLS3P63-125 R2	45 IN-LB
DS1 LK4JU3CN 100A	36 IN-LB
DS1 LK4MU3N 200A	200 IN-LB
M1/ M2 T1, T2 & T3	15 IN-LB

UL #:	E320866
TOTAL FLA:	66 A
LARGEST MOT. FLA	32 A
VOLTAGE:	208/240/480 VAC
PHASE:	3 PH
FREQUENCY:	60 Hz
ENCLOSURE TYPE:	3R
SHORT CIRCUIT CURRENT:	5KA RMS SYMMETRICAL 600V MAXIMUM

DRAWN BY:	JED	DATE:	08/28/20
APPROVED BY:	DO	DATE:	06/19/24
THIS DRAWING CONTAINS PROPRIETARY INFORMATION AND SHALL NOT BE USED OR DISCLOSED WITHOUT PRIOR WRITTEN AUTHORIZATION.			



TITLE: TRD-T33 SCHEMATIC			
SIZE: B	DWG NO.: 1838	PART NO.:	REV: F
SCALE: NONE		SHEET: 2 OF 2	